

Signal-Powered SPH-100 Digital Peak Speed with Memory Tachometer



FEATURES

- Designed for steam turbines, turbochargers, and other high speed applications.
- Holds last ten (10) peak speed readings.
- Time/date stamps speed in real time.
- Provides total run time (hourmeter function).
- Signal and power derived from magnetic pickup.
- CSA approval for Class I, Division 1, Groups A, B, C, D.
- Field-configurable.
- 1 RPM resolution
- High shock, vibration, and moisture resistant.
- Standard SAE case size fits panels with 3-3/8 inch (86mm) openings.
- Gasketed and spray-proof.

*THIRD PARTY APPROVALS

SPH-100



Canadian Standards Association
(CSA): Class I, Division 1, Groups
A, B, C, & D with M204 and M205.

SPECIFICATIONS

EXTERNAL POWER REQUIREMENTS:

No external power required. Power is generated by magnetic pickup.

DISPLAY:

Five active digits (0 to 99999), LCD display; character height of 0.5 inches (13mm).

INPUT SIGNAL VOLTAGE:

Minimum signal amplitude is 4.0 VRMS.

TEMPERATURE RANGE:

Operating: -5°F to +158°F (-20°C to +70°C).

Storage: -40°F to +195°F (-40°C to +90°C).

ACCURACY:

One RPM resolution; within 0.5% (0.1% typical at room ambient) under all combined environmental conditions.

MAGNETIC PICKUPS:

Dynalco magnetic pickup model M204 and M205 are recommended.

OUTLINE AND CONNECTION DRAWING

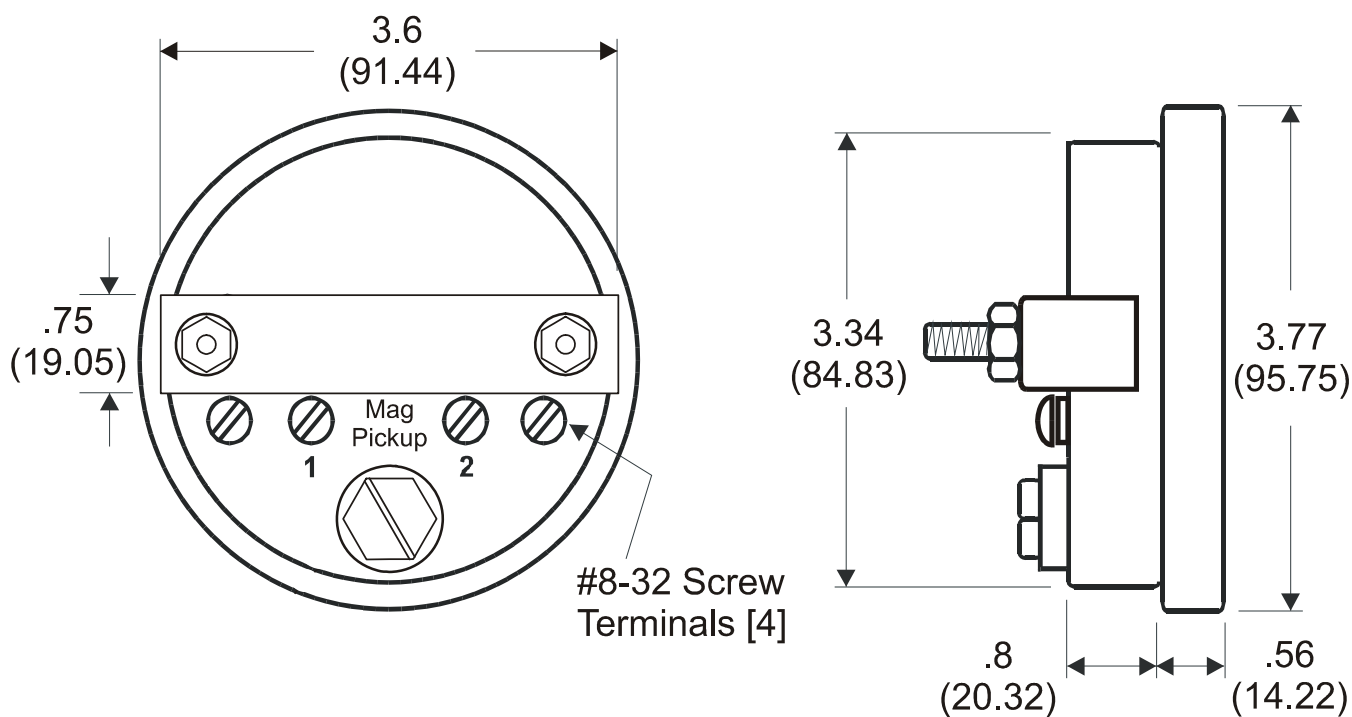

Dimensions in inches
(millimeters)

DYNALCO

CRANE

A division of Crane Co.

Toll Free 800.368.6666 (US & Canada) • Tech Support 800.950.2382
Main 954.739.4300 • Fax 954.484.3376 • www.dynalco.com
3690 NW 53rd Street, Ft. Lauderdale, FL 33309 USA