

PNT-202

Pickup-Powered, 2 Setpoint

Overspeed Trip



Class I, Division 1,
Groups A, B, C, and D

Derives signal and power from two Dynalco magnetic pickups. No external ac or dc power required.

OVERVIEW

When the preset overspeed setpoint is reached, the PNT-202™ trips the SPV-200™ Solenoid Pneumatic Valve. The valve opens, latches, bleeds to the atmosphere, and shuts down the engine if it is connected to the engine pneumatic control system. The PNT-202 also effects shutdown when one of the pickup signals disappears or when an attempt is made to start with only one operational pickup.

The second setpoint can trip the same valve or a separate valve. It can be field-programmed as an underspeed setpoint or as a second overspeed setpoint or crank disconnect. When set for underspeed, no inhibit is necessary on start-up as this setpoint becomes enabled only when the speed first exceeds the setpoint.

FEATURES

- Operates from two (2) Dynalco magnetic pickups. *Single pickup operation is not reliable.*
- Built-in flashing LED indicates when sufficient signal amplitude is available to power the PNT-202.
- Auxiliary output drive provided for Dynalco Controls signal-powered digital tachometers such as the SPD-100 and SPD-700.

DYNALCO CONTROLS

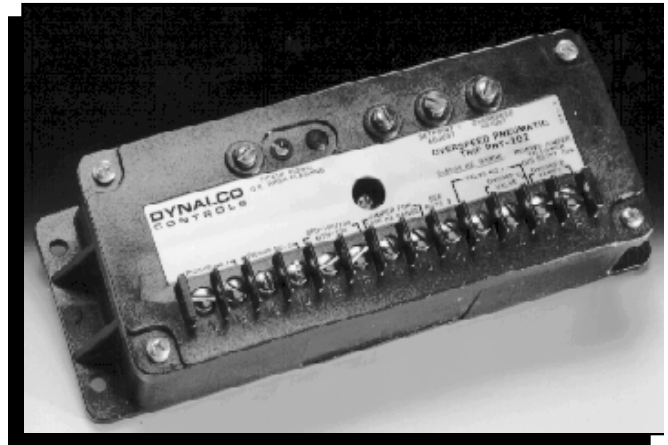

- Totally floating and isolated input terminals are free of grounds.
- Insensitive to line noise, spikes, grounding, etc. since there is no ac or dc connection. Usable in remote locations where no external power is available.
- Rugged, reliable, highly accurate. Senses pulse rate *only*; is insensitive to signal amplitude variations. Stability of $\pm 1\%$ under all environmental conditions. Multiturn setpoint potentiometer permits large speed range adjustment. Field-programmable for input range of either 0-1000 Hz or 0-5000 Hz.
- Foolproof; no panel controls. A single tell-tale reset button pops out from the SPV-200 Solenoid Pneumatic Valve when tripped. Button is pushed back in to reset. Pneumatic reset is available.
- Can drive an optional circuit breaker (in place of the SPV-200 Valve) for "electrical" shutdown applications e.g. grounding the ignition.
- Built-in test circuit. (1) Removing the jumper from the two Verify terminals (N and P) lowers the overspeed trip point 10%, permitting shutdown testing without overspeeding. (2) This feature can also be used to set the trip point to *just trip* at normal operating speed with the jumper disconnected. When the jumper is reinstalled, the overspeed trip is known to be set 10% *higher* than normal operating speed.

SPECIFICATIONS

Two Setpoints: The second setpoint in the PNT-202 is normally set to trip on underspeed, i.e. to trip as the setpoint is crossed on decreasing speed. No external inhibit is necessary on start-up as the underspeed setpoint becomes enabled only when the speed first gets above the setpoint (Class C logic: active once normal).

This setpoint can also be set up as another overspeed setpoint or crank disconnect (trip as the setpoint is crossed on increasing speed) by jumpering terminals K and N. Setpoint outputs can trip two separate SPV-200 Solenoid Valves or a single valve connected to M and N if terminals L and M are jumpered.

Trip Points Adjustment Range: 10% to 100% of input range. Input range is either 0-5000 Hz or, with terminals H and J jumpered, 0-1000 Hz. Range should be restricted to 20-100% of full-scale for 1% accuracy, or 10-100% of full-scale for 2% accuracy. Adjustment via a high-resolution 25-turn potentiometer accessible through a covered hole.

Test Verify: Removing the jumper from terminals N and P lowers the overspeed trip point by 10%.

Required Magnetic Pickups: Dynalco M203 or M204 pickups sensing from a ring gear or other gear with a diametral pitch of 10 or coarser. Best performance at low speeds and best start-up response time is obtained with the narrowest possible pickup-to-gear gap. Operation with two pickups provides missing signal protection, i.e. engine shutdown when one of the signals is missing. *Do not operate with one pickup.*

Response Time: 150 milliseconds under running conditions. On start-up from zero speed, trip response may take up to one second depending on engine ramp speed and/or pickup-to-gear spacing.

Input Signal Voltage: Minimum pickup signal amplitude required is 3.5 Vrms (7 volts peak-to-peak). Any test signal used to replace a pickup should be current-limited to 30 mA, maximum.

Isolated Circuit: All circuitry is totally floating i.e. totally isolated and insulated from the case and from ground.

Operating Environment Temperature: -20°F to +160°F (-29°C to +71°C).

Trip Point Stability: ±0.01%/°F/°C typical; no change with signal amplitude for signal levels above 2.5 Vrms.

Flashing LED: An integral LED flashes every two seconds when there is enough energy stored in the

internal dc supply capacitors to trip the solenoid valve connected to the PNT-202. Since the pickups feed the supply, the flashing LED indicates that there is sufficient signal amplitude to operate either unit.

The flashing LED also denotes a ready or armed condition, and it can also be used to determine the lowest speed at which the system becomes armed. The LED does *not* flash with sustained overspeed or missing signal since the internal supply capacitors are discharged and charged repetitively (repetitive pulsing to the solenoid valve) under such conditions.

SPV-200 Pneumatic Valve Ratings: Input pressure of 40-100 psig, 20 cfm at 100 psig. Dry, clean instrument air filtered to 40 microns is required.

Output Drive to Digital Tachs: Conditioned square wave output at terminals E and F to drive Dynalco self-powered digital tachometers, e.g. SPD-100 and SPD-700. This output is inhibited when there is insufficient pickup signal amplitude, i.e. less than 3.5 Vrms.

Breaker Drive Capability: The SPV-200 Solenoid Pneumatic Valve can be replaced with a magnetic circuit breaker to achieve shutdown by grounding the ignition or by letting auxiliary breaker contacts drive a shutdown solenoid. Terminals N(+) and M(-) or N(+) and L(-) will trip a 200 mA breaker with a coil resistance of 15 Ω or less. When breaker contacts are used for shorting the ignition, 50 Ω series limiting resistors should be used to limit inrush currents.

Weight:	PNT-202	1.4 lbs (0.64 kg)
	SPV-200	1.8 lbs (0.82 kg)

HOW TO ORDER

SPECIFY:

1. PNT-202 (two setpoints).
2. Range: 0-1000 Hz or 0-5000 Hz.
3. Magnetic pickups: two M204 (2.5 in. of thread), or two M203 (4 in. of thread).

OPTIONS:

- a. SPV-200 Solenoid Pneumatic Valve.
Indicate quantity required.
- b. 200 mA Circuit Breaker (p/n 50A3).

ELECTRICAL CONNECTION AND OUTLINE DRAWING

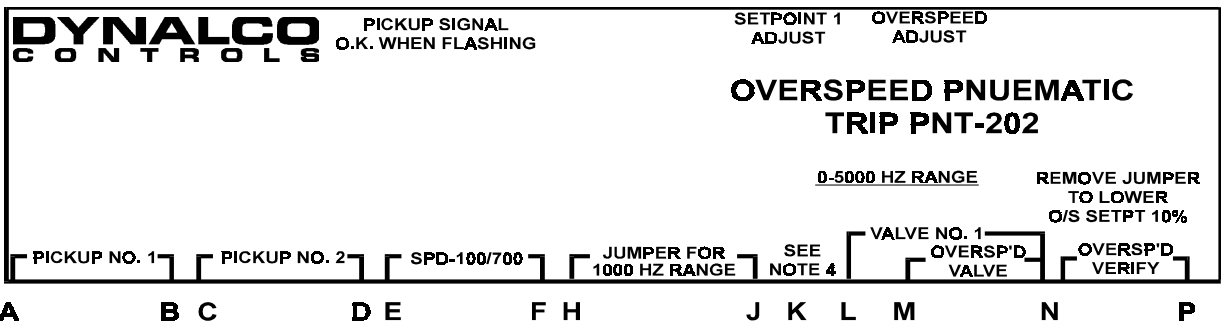

Dimensions in inches (cm)

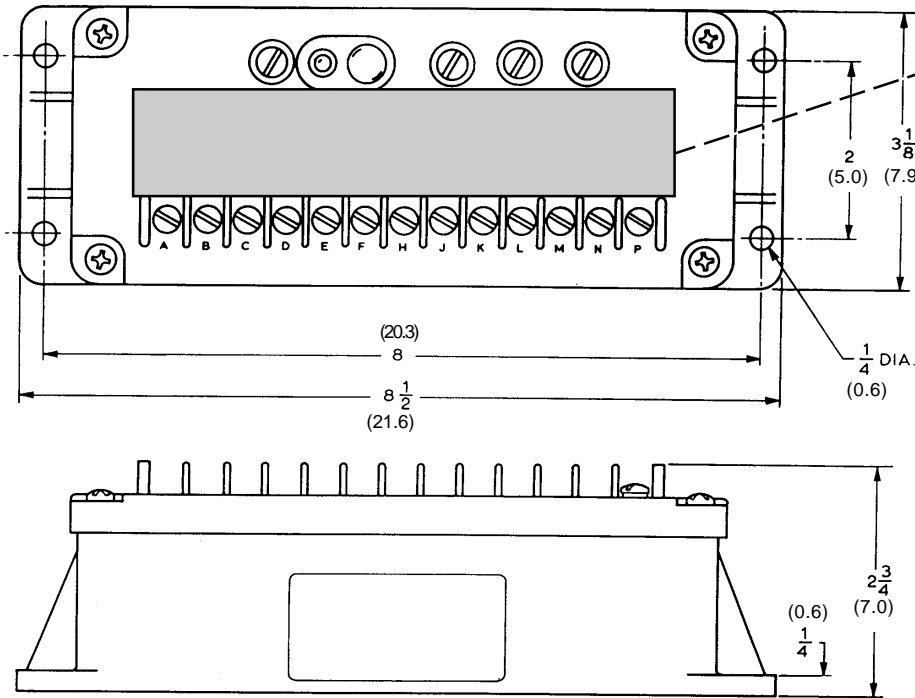

ELECTRICAL CONNECTION NOTES:

1. Do not operate from one magnetic pickup.
2. Use minimum gap on pickups; gap both equally.
3. Connect signal cable shields to ground.
4. Setpoint 1 modes: jumper K to N to trip above the setpoint. Remove jumper to trip below setpoint.
5. To drive a single valve from both setpoints, jumper L to M.

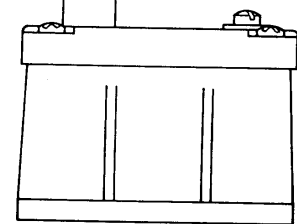

PNT-202 Overspeed Shutdown Trip

NOTE

As with any primary shutdown device, the PNT-202 should be tested regularly for proper shutdown operation. Each of the following should be tested:

1) Test for actual overspeed shutdown. Using a signal generator (e.g., Dynalco F-16) with an amplitude of 3 Vrms or greater, or any other

suitable means, ensure that the PNT-202 does cause a shutdown during an overspeed condition.

2) Disconnect one lead from one magnetic pickup and ensure that the PNT-202 causes a shutdown. Do the same with the other pickup.

ELECTRICAL CONNECTION AND OUTLINE DRAWING

Dimensions in inches (cm)

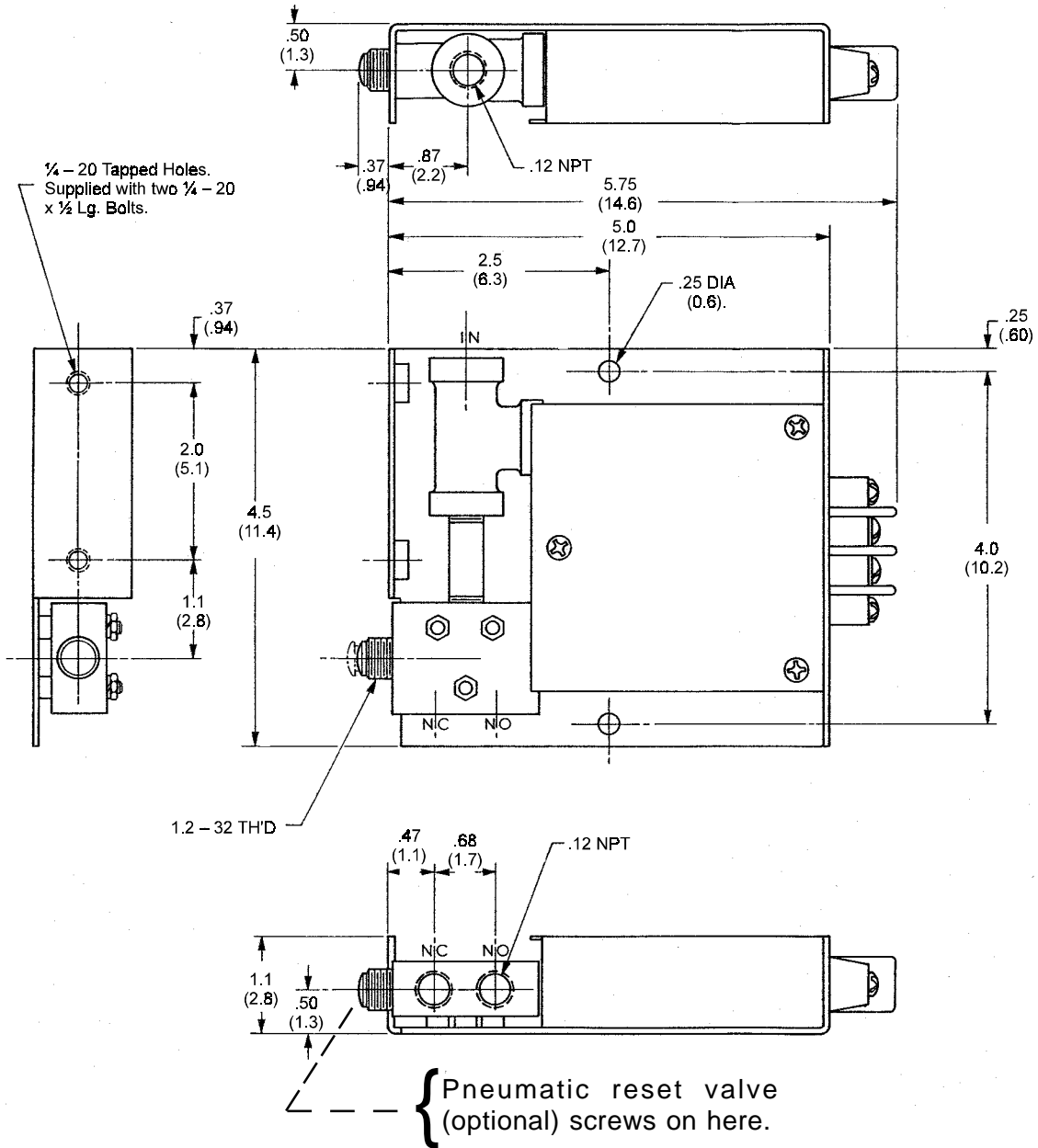

SPV-200 Solenoid Shutdown Valve

CRANE DYNALCO CONTROLS

PNT-202 and SPV-200 are trademarks of Dynalco Controls.
 DYNALCO CONTROLS RESERVES THE RIGHT TO CHANGE THESE SPECIFICATIONS WITHOUT NOTICE.
 FOR COMPLETE SPECIFICATION INFORMATION CONTACT A DYNALCO REPRESENTATIVE.