

# LST-100

## Digital Tachometer

The LST-100™ Series features a field-selectable pulse rate multiplier that can increase signal pulse rate by a factor of 10 or 100. The units are particularly useful when input frequency is low, resulting in too slow an update rate (gate time), or for applications where signal amplitude is minimal because of low shaft speed or large pickup-to-gear gap.



### FEATURES

- Standard SAE case fits engine panels with 3.37 inch (8.6 centimeter) openings.
- Highly shock and vibration resistant. Gasketed and spray-proof.
- Universal: Can be field-calibrated for any number of pulses per revolution from the sensor.
- Ideal for OEM use. Can be paralleled with governors and/or speed switches.
- High immunity to electrical noise.
- Display contrast increases with increasing ambient light; ideal for both indoor and outdoor installation. Units are also available in lighted versions (LST-100L or LST-108L).
- The pulse rate multiplier increases input frequency which permits calibration at a much shorter gate time.
- Tachometer can be factory configured for different input types i.e. TTL, CMOS, magnetic pickups, etc. Specify which type when ordering.

### SPECIFICATIONS

- **Power Requirement:** 10 to 30 Vdc or 115 Vac  $\pm 10\%$ , 50/60 Hz, 8 mAdc typical. LST-100L and LST-108L are powered with 20 to 30 Vdc only.
- **Display:** 4 active digits (0 to 9999), non-blinking LCD display, character height of 0.5 inch (1.3 centimeters).
- **Input Signal Frequency:** Signal frequency up to 10,000 Hz, except contact closure.
- **Contact Closure Input Option:** 0-200 Hz.
- **Input Signal Voltage:** 25 mVrms sensitivity for the standard unit which accepts zero crossing waveforms from pickups, generators, and pulsers. Nominal input resistance of 10 k $\Omega$ . Maximum permissible signal 50 Vrms. TTL option accepts unidirectional positive pulses from 0 to +5 volts, up to 0 to +15 volts.
- **Signal Common:** Signal common is tied internally to the negative side of the dc supply.
- **Operating Environment:** (operating)  $-5^{\circ}\text{F}$  to  $+175^{\circ}\text{F}$  ( $-20^{\circ}\text{C}$  to  $+80^{\circ}\text{C}$ ); (storage)  $-40^{\circ}\text{F}$  to  $+195^{\circ}\text{F}$  ( $-40^{\circ}\text{C}$  to  $+90^{\circ}\text{C}$ ).

- **Accuracy:** 1 RPM resolution, within  $\pm 0.5\%$  ( $\pm 0.1\%$  typical at room ambient) under all combined environmental conditions.
- **Gate Time Adjust:** Gate time is set by selecting one of four ranges on a switch and by a 25-turn vernier control potentiometer. Both controls are accessible from the back of the tachometer through a plugged hole.
- **Gate time ranges (LST-100 & 100L):**  
(1) 0.26–0.72; (2) 0.72–1.43; (3) 1.43–2.8; (4) 2.85–5.70.
- **Gate time ranges (LST-108 & 108L):**  
(1) 0.13–0.36; (2) 0.36–0.72; (3) 0.72–1.43; (4) 1.43–2.85.
- **Recommended Magnetic Pickups:** Dynalco Controls magnetic pickup M102 is used with the LST-100 Series in most applications. For very low speed applications the Dynalco Controls ultrahigh sensitivity M142 and the zero-velocity M910 are recommended. Refer to the Dynalco Controls Magnetic Pickups Brochure for a description of these and other pickups.
- **Weight:** 0.8 pounds (0.36 kg)

## OUTLINE AND CONNECTION DRAWING

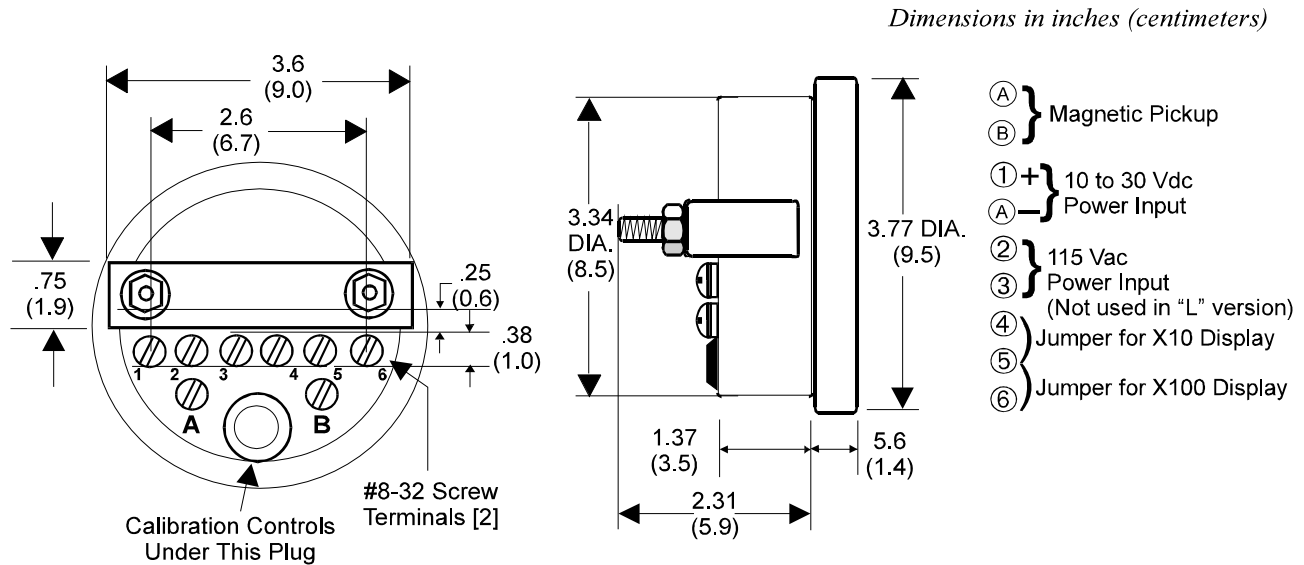

**CRANE**

A division of Crane Co.

**DYNALCO**

Toll Free 800.368.6666 (US & Canada) • Tech Support 800.950.2382  
Main 954.739.4300 • Fax 954.484.3376 • www.dynalco.com  
3690 NW 53rd Street, Ft. Lauderdale, FL 33309 USA