

DPM-105

Universal Digital Panel Meter

The DPM-105™ displays speed, temperature, rate, or virtually any variable type, in corresponding engineering units. 0–1 mA input only. Replaces analog panel meters for greater accuracy, readability, and reliability. Use as readout for Dynalco speed and temperature transmitters, and as a remote tachometer.



See "Third Party Approvals"

- **Universal, Field-Adjustable:**
Adjustable readout ranges from zero to 1999, with integral multi-turn span potentiometer.
- **Third Party Approvals:** (Intrinsic Safety)
CSA: Class I, Division 1, Groups A, B, C, & D, rated 8–40 Vdc, 10 mA maximum. Meets standards for intrinsic safety, when connected to CSA certified Zener barrier devices per Dynalco drawing B8008843.

ABS: Certificate No. 92-QE-10237-X.

FEATURES

- **Rugged:** No meter movement; all solid-state. Standard SAE case fits panels with 3-3/8" openings.
- **Sealed:** Resistant to sour gas and moisture that attack springs in an analog meter movement.
- **Large 0.4" High Digits:** Liquid Crystal Display, 1-digit resolution. Display contrast increases with increasing ambient light. Ideal for outdoor installations.
- **Auto Zero:** Readout is "0000" at zero input with power applied. The unit can be calibrated from 0 to any display range up to 1999. The meter indicates negative only when the signal goes negative. Positive and negative read-outs follow the polarity of the input signal.
- **Power:** Can be powered from 8 to 40 Vdc. Consumes only 0.5 mA at 9 V.
- **Signal:** Accepts grounded and ungrounded signal sources.

SPECIFICATIONS

Display: 3½ active digits, optional fixed zero for 4½ digit display; optional decimal point after first, second, or third digit. Fixed zero and optional decimal point and fixed zero set by internal component board switch.

Span Adjust: Twenty-five turn potentiometer permits adjustment of the display to any desired span from zero to 1999 (3½ digits). A fifth digit (dummy zero) can be turned on for readouts up to 19990 (4½ digits).

Environment Temperature: 0°F to +165°F (-18°C to +74°C).

Accuracy: 0.1% linearity, 0.5% stability over the environment range.

Input Signal: 0 to 1 mAdc.

Input Resistance: 95 Ohms.

Power Requirement: 8 to 40 Vdc. (Typical current consumption of 0.5 mA at 9 Vdc; 1 mA at 12 Vdc; 4 mA at 24 Vdc; 6 mA at 32 Vdc).

Weight: 1 lb (0.45 kg)

OUTLINE DRAWING

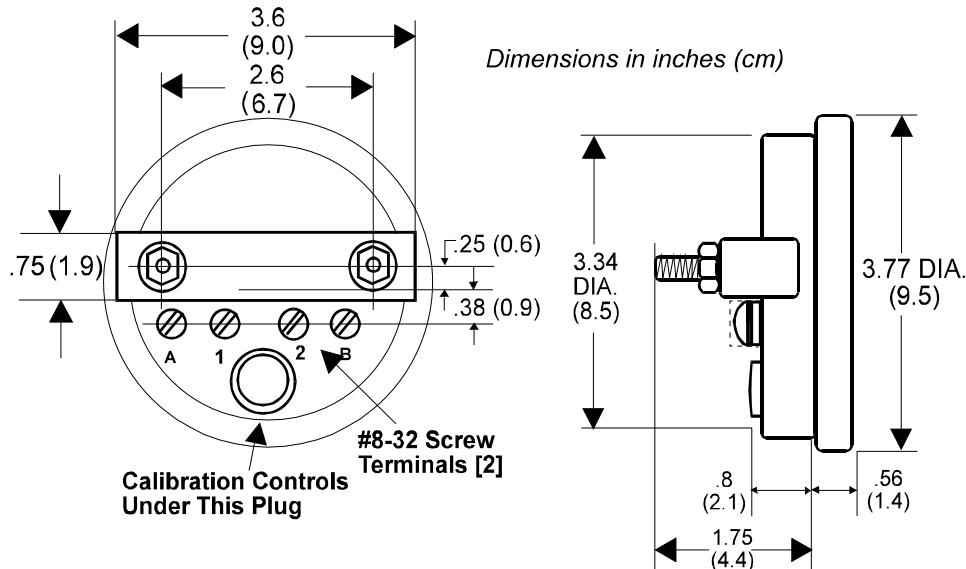

WIRING CONNECTIONS FOR INTRINSIC SAFETY

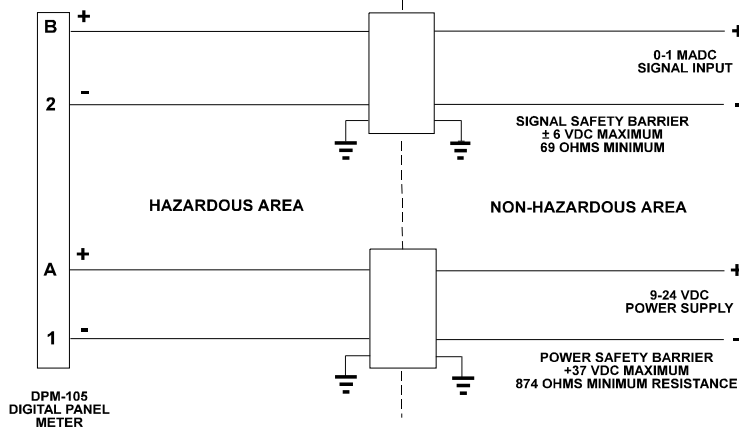

DRAWING B8008843

DYNALCO



A division of Crane Co.

Toll Free 800.368.6666 (US & Canada) • Tech Support 800.950.2382
 Main 954.739.4300 • Fax 954.484.3376 • www.dynalco.com
 3690 NW 53rd Street, Ft. Lauderdale, FL 33309 USA