

2. Starting operations

Only assemble or disassemble the device when depressurized!

- The flow switch should be installed and operated only by authorized persons.
- Cover and bottom of the device are a function unit. Changing the parts may cause measuring errors or malfunction. See serial number inside the cover. For wall mounting the back of the device has to be mounted with appropriate screws. By loosening the both backside screws the unit is rotatable in steps of 90° and can also be mounted separately (recommended in case of strong vibrations).
- The electrical connection (power supply, analog output and switching contacts) acc. connection chart.
- Connect the fittings with the pipe. For sealing use the attached Klingsil seals only.
- Mounting of the device according to the flow direction (arrow on the back).
- Connect pipe and fittings manually.
- Tighten both fittings against one another.

During operation air bubbles in the system may affect measuring.

Please flush the system after installation or ventilation with >3 l/min; 0,8 gpm.

The operating pressure must not exceed 1 bar.

Please follow the national and international regulations for the installation of electrotechnical systems.

Power supply acc. EN50178, SELV, PELV.

Switch off the system and connect the device as follows:

Connection Chart

Plug M 12 x 1, 4 pin	Version with 2 switching outputs (DESINA®-version)	Version with 2 switching outputs and 1 analog output
Pin 1	+Ub (15...32 V DC)	+Ub (15...32 V DC)
Pin 2	SP2 (0,5 A max.)	analog
Pin 3	0 V	0 V
Pin 4	SP1 (0,5 A max.)	SP1 (0,5 A max.)
Pin 5		SP2 (0,5 A max.)

Connection Scheme

see page 3 top

Barksdale
CONTROL PRODUCTS

Barksdale GmbH
Dorn-Assenheimer Strasse 27
D-61203 Reichelsheim / Germany

Tel.: +49 - 60 35 - 9 49-0
Fax: +49 - 60 35 - 9 49-111 and 9 49-113
e-mail: info@barksdale.de
www.barksdale.de

Art.-Nr.: 923-1313
Index C, 25. 01. 2005 Software version: 1.0
Specifications are subject to
changes without notice.

Barksdale Inc.
3211 Fruitland Ave.
Los Angeles, CA - 90058 - 0843

Phone: (323) 589 6181
Fax: (323) 589 3463
e-mail: sales@barksdale.com
www.barksdale.com

Operating Instructions Ultrasonic Flow Sensor UQS 7

Dimensions (in mm)

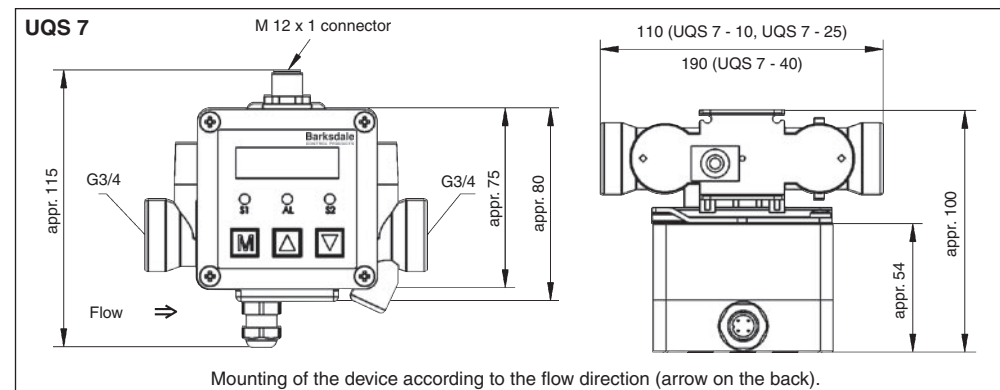

1. Product description

- The device measures the flow rate of water and watery emulsions, monitors the actual process values on a display and generates 2 switching signals and 1 analog signal according to the preset configuration.
- According to DESINA® standard.
- The instruments must only be installed in systems where the maximum pressure Pmax or the maximum temperature Tmax is not exceeded (according to the values on the type label).
- **Attention:** This device is not designed to be used as the only safety relevant element in pressurized systems according PED 97/23/RC.

Display	Actual flow rate in l/min, m³/h, gallons/min (gpm) or gallons/h (gph), 4-digit display, the display unit has to be programmed.	
Evaluation	Actual flow	
Signal output	Output 1	Switching signal: peak value for flow rate; Hysteresis- or window function; NC or NO.
	Output 2	Switching signal: peak value for flow rate; Hysteresis- or window function; NC or NO.
	Analog output	Analog signal 4...20 mA or 0...10 V DC

Measuring ranges	UQS 7 - 10	UQS 7 - 25	UQS 7 - 40
Flow rate in l/min	0,04...10	0,1...25	0,16...40
Flow rate in m³/h	0,0024...0,6	0,006...1,5	0,0096...2,4
Flow rate in gpm	0,01...2,64	0,026...6,6	0,042...10,6
Flow rate in gph	0,63...158,5	1,58...396,3	2,53...634

Pressure drop (dP)
depending on the
flow rate (Q).

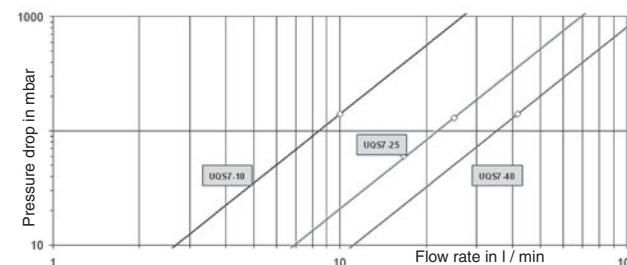

Max. permitted flow rate:

- 70 l/min (4,2 m³/h)
- 18,5 gpm (1110 gph)

Connection scheme

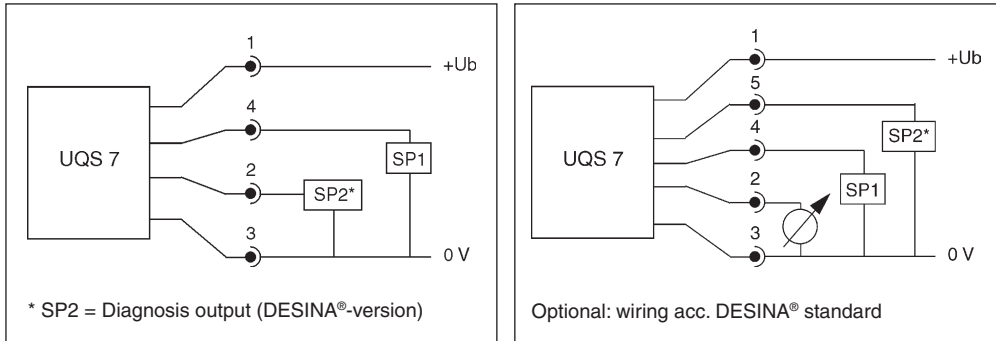

3. Operation

The display monitors the actual flow rate, the green LEDs display the switching mode of the outputs.

After the unit is switched on, the unit starts an automatic self-test.

The device is menu operated and configured by the three keys on the front.

With the „M“ key (= mode) you change between the operation / indicating level to the dialog values and the adjusted / actual values. With the keys („↑“ = up) and („↓“ = down) you change between the dialog values in the menu or change the values / functions in the menus.

A change of any configuration starts always with the M-Mode and indicated by the flashing cursor. After a change has been made the M-mode key must be pressed to confirm each configuration; to set numbers, each digit has to be confirmed with the M-Mode before adjusting the next one. By confirming the last digit the new configuration will be stored in the memory.

Pushing the down key at the end of the sub-menu the software will switch automatically to the main menu. If the dialog is not continued within two minutes the device automatically returns to the measuring mode. Activating the („↑“ = up) and („↓“ = down) keys together for more than 5 seconds will block any changings in all menus. In this mode, all configuration values can be checked only, but not changed. Repeating this action will unlock the configuration menu.

4. Programming

The setting menu is activated with the **mode** key. The dialog items are selected with the „↑“ and „↓“ keys. If the mode key is pressed again the corresponding value for the dialog item is shown and can be altered with the „↑“ and „↓“ keys.

If the dialog with the unit is not continued within two minutes the device automatically returns to the measuring mode without accepting the new values.

To terminate programming more quickly, you can switch back to the measuring mode (primary menu) from any item in the menu by holding the M-key pressed for five seconds.

If the key lock has been activated, the values can be shown, but no changes made. („Lock“ appears in the display when an attempt is made to change values). The key lock is activated by pressing the „↑“ and „↓“ keys simultaneously for at least five seconds. Press again to deactivate the key lock again.

List of functions

Main Menu	Sub Menu	Value	Description
Measuring mode	Display of the actually measured value and the measuring unit
nEnd			Display keylock No keylock, all parameters can be adjusted Keylock active, all parameters visible but cannot be changed
dISP	SI Unit		Display menu Adjustment of the measuring unit Activation of the unit display
PEAK	nAH CLRH no YES	Peak value menu Display the peak value memory No deletion Delete the peak value memory
SP 1 ... SP2	nODE On OFF Stu LEu	Std u in Err 0,0 s...99,9 s	Switchpoint menu SP1...SP2 Standard evaluation (rising/falling) Window technology Error outputs Switch-on value for SP1...SP2; if the ON-value is smaller than the OFF-value, the switch evaluation is falling Switch-off value for SP1..SP2 Startup delay (0 = deactivated) Inversion of the switching output
	dS 1 dr 1 dS2 dr2	HFS LFS 0,0 s...9,9 s 0,0 s...9,9 s 0,0 s...9,9 s 0,0 s...9,9 s	High-level-fail-safe (Normally Open function) Low-level-fail-safe (Normally Closed function) Switch-on delay for SP1 in seconds Switch-off delay for SP1 in seconds Switch-on delay for SP2 in seconds Switch-off delay for SP2 in seconds
AnAO	AnOP AO2S AOFS	On OFF	Analog output menu Analog output in operation Analog output switched off Scale the analog output - start value (e. g. 0 l/min = 4 mA) Scale the analog output - end value (e. g. 40 l/min = 20 mA)

5. Error handling

If the device detects an error during the internal self-check or operation it is monitored by the flashing (yellow) alarm-LED. The error can be read out in the menu (Err).

Display	Error	Display	Error
OH	no error	CL	calibration error
nAH	exceeding positive measuring range	ono	error analog output
nIn	exceeding negative measuring range	OCIn	sensor too dirty or without media
SP 1	error switching output 1	OCOn	sensor error
SP2	error switching output 2		
dot	data error (EEProm)		

