

# 55581 Series

Linkless Cabin Air  
Suspension Leveling Valve



- ▶ Engineered for high temperature environments
- ▶ Precise dead band optimizes cabin height control

**Barksdale**

CONTROL PRODUCTS

**CRANE** Barksdale, Inc./Barksdale GmbH  
A Subsidiary of Crane Co.

# Linkless Cabin Air Suspension leveling Valve

## 55581 Series

The Barksdale 55581 Linkless Cab Valve (LCV) is the latest generation of cabin air suspension leveling solutions from North America's leading heavy vehicle air suspension valve supplier. The LCV combines valve and linkage into a compact, lightweight unit. High temperature, engineered polymer construction stands up to the extreme operating environments generated by emission controls. Compact linear design minimizes the valve footprint, allowing greater cabin suspension design freedom. Nitrile seals provide years of reliable service.

Press on mounting points and push to connect DOT/SAE fittings minimize installation time. The LCV is permanently sealed, eliminating maintenance and unauthorized adjustment.

The LCV is available in multiple port configurations with 1/4" or 6mm push to connect fittings and standard or micro-adjust bushings.

### Features

- ▶ Value
  - Combined valve and link design
  - Engineered plastic construction
- ▶ Performance
  - Engineered for extreme temperatures
  - Precise deadband optimizes cabin height control
  - Corrosion resistant
- ▶ Reduced installation cost
  - Press on mounting points
  - Push to connect tubing connections
  - Fixed length / no adjustment required

### Applications

- ▶ Semi tractor cabin air suspension

### Technical Drawings

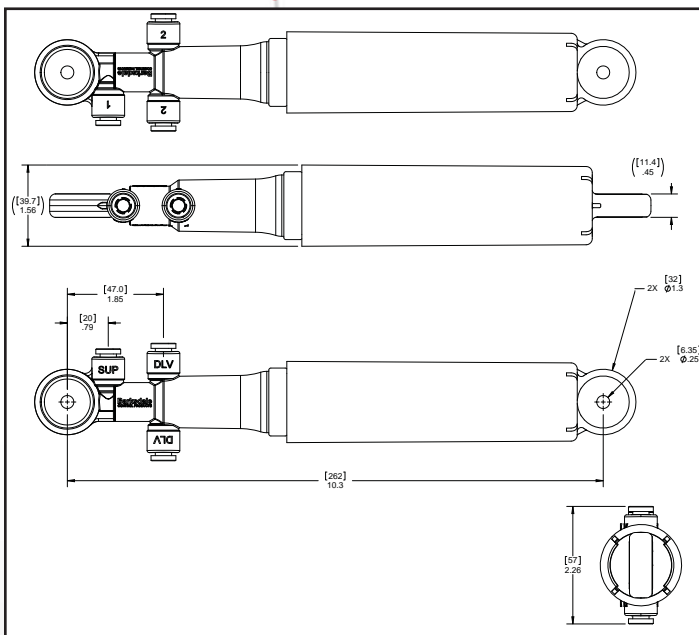

### General Specifications

<b>Operating Media:</b>	Air
<b>Seal Type:</b>	Poppet
<b>Operating Pressure:</b>	150 PSI (10 bar) maximum
<b>Operating Temperature:</b>	-40°F to +230°F (-40°C to +110°C)
<b>Maximum Flow Rate:</b>	50 SLPM (standard liters per minute)
<b>Port Size:</b>	1/4" Push-to-connect* 6 mm Push-to-connect* * DOT FMVSS 571.106 and SAE J2494-3 compliant
<b>Port Configuration:</b>	Single supply port Single or dual delivery ports 0 and 180 degree port alignment
<b>Materials of Construction:</b>	Structural components: Internally lubricated high temperature polymer Sealing surfaces: Thermoset nitrile
<b>Weight:</b>	.39 lbs. (180 grams)

### Flow Curve

#### LINEAR CAB VALVE FLOW

Pressure @ 135 psi

